

### FLORA'S FANCY 8x32 J

|   |               |  |   |
|---|---------------|--|---|
| S | <br><b>RA</b> |  | 2 1 3<br><b>ST</b> $T_{R4}^3$<br>2 1 3<br><br><b>LA</b> |
|---|---------------|--|---|

RSCDS Tucson & Seven Pipers Scottish Society, RSCDS Book 49.8

3C/4C longwise set.

### SWISS LASSIE 8x32 R

|                                 |  |           |                                       |                                       |
|---------------------------------|--|-----------|---------------------------------------|---------------------------------------|
| 2 1<br><br><b>T</b> $R_{1/4}^1$ |  | 1 3 2<br> | 3 2<br><b>T</b> $R_{1/2}^1$ <b>RA</b> | 1 2<br><b>T</b> $R_{1/2}^1$ <b>RA</b> |
|---------------------------------|--|-----------|---------------------------------------|---------------------------------------|

Rosi Betsche, RSCDS Book 39.1

3C/4C longwise set.

### LINNEA'S STRATHSPEY 8x32 S

|   |  |                          |                               |
|---|--|--------------------------|-------------------------------|
| S   |  | S S                      | S                             |
| Chaperoned Chain Progression<br><br><b>T</b> $R_{4}^3$ <b>T</b> $R_{4}^3$ |  | <br><b>T</b> $L_{1/2}^1$ | 3 1 2<br><b>A</b><br>to 2 1 3 |

Tim Wilson, 2001, Dunsmuir Dances, RSCDS Book 47.2

3C/4C longwise set.

### AIRD OF COIGACH 4x48 J

|                           |                           |                           |                           |
|---------------------------|---------------------------|---------------------------|---------------------------|
|                           | 8                         |                           |                           |
| Snowball Chain            |                           |                           |                           |
| <br><b>X</b> <sub>R</sub> | <br><b>X</b> <sub>L</sub> | <br><b>X</b> <sub>R</sub> | <br><b>X</b> <sub>L</sub> |

John Bayley, 1975, Imperial Book 3.13

4C/4C longwise set.

### THE SAILOR 8x32 R

|              |              |              |                     |
|--------------|--------------|--------------|---------------------|
| <br><b>S</b> | <br><b>S</b> | <br><b>S</b> | 1x<br><br><b>RL</b> |
|--------------|--------------|--------------|---------------------|

RSCDS Book 24.4

3C/4C longwise set.

### HEATHER DEWAR 4x32 S

|                                       |                           |                           |   |
|---------------------------------------|---------------------------|---------------------------|---|
| Set and Rotate<br>1 2<br><br><b>S</b> | <br><b>X</b> <sub>R</sub> | 2 1 3 4<br>               | <br><b>X</b> <sub>R</sub> 1 <b>X</b> <sub>R</sub> 1 |
| <br><b>X</b> <sub>R</sub>             | <br><b>X</b> <sub>R</sub> | <br><b>X</b> <sub>R</sub> | <br><b>X</b> <sub>R</sub>                           |

Evelyn Ramwell, 1997, Kirkbrae Collection 2

4C/4C longwise set.

### TRIBUTE TO THE BORDERS 8x32 J

|  |          |          |          |
|--|----------|----------|----------|
| $X_R \curvearrowright 1 T_{R1\frac{1}{4}}$ |          |          |          |
| <b>S</b>                                   | <b>S</b> | <b>S</b> | <b>S</b> |

Roy Goldring, 1979, RSCDS Leaflet 11 3C/4C longwise set.

### BLUE BUTTERFLY 3x32 S

|                        |                        |                        |
|------------------------|------------------------|------------------------|
|                        |                        |                        |
| <b>T<sub>3/4</sub></b> | <b>T<sub>3/4</sub></b> | <b>T<sub>3/4</sub></b> |

Chris Brooks, 1999 3C/3C longwise set.

### THE SALTIRE SOCIETY REEL 8x32 R

|                         |                         |                         |                         |
|-------------------------|-------------------------|-------------------------|-------------------------|
|                         |                         |                         |                         |
| <b>T<sub>R3/4</sub></b> | <b>T<sub>L3/4</sub></b> | <b>T<sub>R3/4</sub></b> | <b>T<sub>L3/4</sub></b> |

|          |          |           |          |
|----------|----------|-----------|----------|
|          |          |           |          |
| <b>S</b> | <b>S</b> | <b>RA</b> | <b>S</b> |

Roy Goldring, 1985, RSCDS Leaflet 9 3C/4C longwise set.

### WELCOME TO DUFFTOWN 8x32 J

|           |          |          |
|-----------|----------|----------|
|           |          |          |
| <b>RA</b> | <b>S</b> | <b>S</b> |

Iccie Stuart, 1987 3C/4C longwise set.

### BONNIE GALLOWA' 4x40 S

|                               |                               |                          |                                       |
|-------------------------------|-------------------------------|--------------------------|---------------------------------------|
| 1 3<br>→ <b>T<sub>B</sub></b> | 1 3<br>← <b>T<sub>B</sub></b> | 1 2 3 4<br><b>RONDEL</b> | ALL 2 1 4 3 1 2 3 4<br><b>S RL XR</b> |
|-------------------------------|-------------------------------|--------------------------|---------------------------------------|

|                      |                      |                      |                      |
|----------------------|----------------------|----------------------|----------------------|
|                      |                      |                      |                      |
| <b>X<sub>R</sub></b> | <b>X<sub>L</sub></b> | <b>X<sub>R</sub></b> | <b>X<sub>L</sub></b> |

Bill Little, 1997, Bonnie Gallowa', Blackadder Collection 4C/4C longwise set

### THE RECUMBENT STONE 5x48 R

|                         |          |          |                         |
|-------------------------|----------|----------|-------------------------|
|                         |          |          |                         |
| <b>T<sub>R3/4</sub></b> | <b>S</b> | <b>S</b> | <b>T<sub>R3/4</sub></b> |

|          |          |           |           |
|----------|----------|-----------|-----------|
|          |          |           |           |
| <b>S</b> | <b>S</b> | <b>RL</b> | <b>RL</b> |

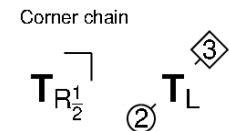
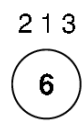

John Drewry, 2000, Greenburn Book 3 5C/5C longwise set.

### THE LAIRD OF MILTON'S DAUGHTER 8x32 J

|                |   |  |                                       |                      |   |
|----------------|---|--|---------------------------------------|----------------------|---|
| <b>S</b> $X_R$ | $\curvearrowright$ <b>T<sub>L</sub></b> | Corner chain<br> | $T_{R\frac{1}{2}}$ $T_{L\frac{1}{4}}$ | $\lrcorner$ <b>R</b> | 2 1 3<br> |
|----------------|---|--|---------------------------------------|----------------------|---|

Lord Craigmyle, RSCDS Book 22.10 3C/4C longwise set.

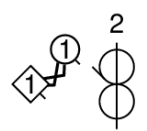
### BUTTERSCOTCH AND HONEY 4x32 S

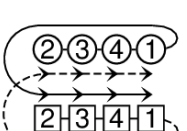
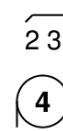
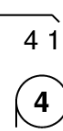
|                     |  |  |  |  |                              |  |
|---------------------|--|--|--|--|------------------------------|--|
| $ST_{R\frac{1}{2}}$ |  |  |  |  | ALL<br><b>ST<sub>B</sub></b> | 2 3 <span style="margin-left: 20px;">4 1</span><br>  |
|---------------------|--|--|--|--|------------------------------|--|

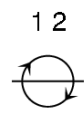
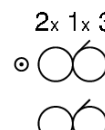
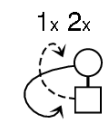

Jean Attwood, Alexander Leaflets 4C/4C longwise set

### SUMMER WOONG 8x32 R

|   |  |  |  |                 |
|---|--|--|--|-----------------|
| 1 2<br> | 1 2<br> | 2x 1x 3<br> | 2x 1x <span style="margin-left: 20px;">1x 2x</span> <span style="margin-left: 20px;">1x 2x</span>                    | 1 2<br><b>P</b> |
|   |  |  | $\xrightarrow{R}$ $\xleftarrow{R}$  |                 |
|   |  |  | 3 bars <span style="margin-left: 20px;">3 bars</span> <span style="margin-left: 20px;">L under own R arm</span>      |                 |

Alan Macpherson, RSCDS Book 38.6 3C/4C longwise set.

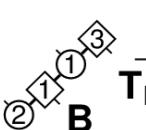
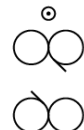
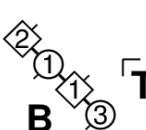
### NAPIER'S INDEX 8x40 J

|  |   |       |   |   |   |                      |
|--|---|-------|---|---|---|----------------------|
| <b>S</b> $\curvearrowright$ $T_{L\frac{1}{4}}$ |  | $T_R$ |  |  |  | <b>X<sub>R</sub></b> |
|  | <b>B</b> <span style="margin-left: 20px;"><b>B</b></span>                           |       |   | <b>B</b> <span style="margin-left: 20px;"><b>B</b></span>                           |   |                      |
|  | 4 bars <span style="margin-left: 20px;">4 bars</span>                               |       |   | 4 bars  |   |                      |

Brian Charlton, 2001, RSCDS Book 45.8 3C/4C longwise set.

### TRIPLE HAPPINESS 3x32 S

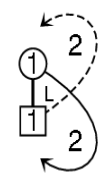
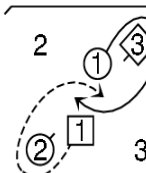
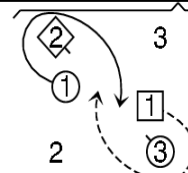
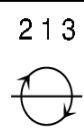
|  |   |                    |   |                                |
|--|---|--------------------|---|--------------------------------|
| $\updownarrow$ $T_{L\frac{1}{2}}$<br>take R hands briefly                          |  | 1 2<br><b>KNOT</b> | Comers Pass & Turn<br> | $T_B$                          |
|  |   |                    | 2 1 3<br>              | 3x 1x 2x<br>$T_{B\frac{1}{2}}$ |

Yoshiki Oyama, 2016, RSCDS Book 52.10 3C/3C longwise set.

### THE HIGHLAND RAMBLER 8x40 R

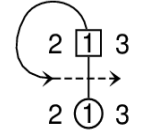
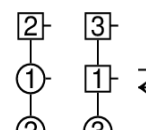
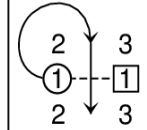
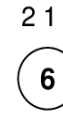
|                              |                  |   |   |   |       |  |
|------------------------------|------------------|---|---|---|-------|--|
| $\curvearrowright$ <b>RA</b> | 1 3<br><b>LA</b> |  |  |  | $T_R$ | 2 1 3<br> |
|------------------------------|------------------|---|---|---|-------|--|

Roy Goldring, 1985, Leeds Silver Jubilee 3C/4C longwise set

### LUCKENBOOTH BROOCH 8x32 J

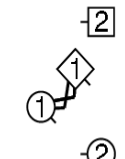
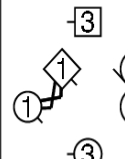
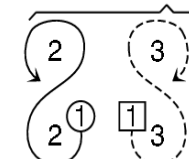
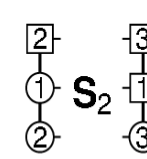
|  |  |  |                  |  |   |
|--|--|--|------------------|--|---|
|  |  |  | 2 3<br><b>RL</b> |  | 1st time:<br>$T_{R\frac{1}{4}}^{13}$<br>to Prom hold<br>2nd time:<br>$T_{R\frac{3}{4}}$ |
|--|--|--|------------------|--|---|

John Bowie Dickson, Glendarroch Sheet 28 3C/4C longwise set.