

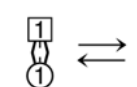

THE HOLLIN BUSS 8x32 J

1 2 ↑ ↓	1 2 T_R¹₂ RA	2 1 ↑ ↓	2 1 T_L¹₂ LA		S  T_R
------------	--	------------	--	---	---

RSCDS Book 24.8

2C/4C longwise set.

LADY SOPHIA LINDSAY 3C & 4C cross on 2nd chord **4x32 R**

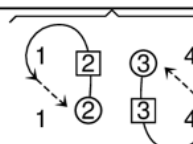
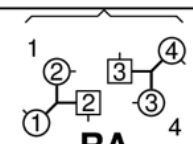
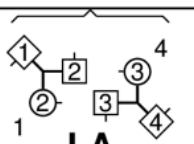
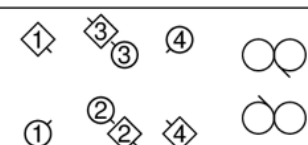
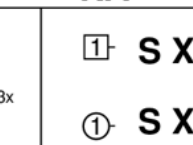
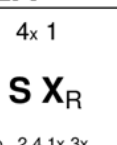
RA 	RA 	LA 
		S X_R 

Jean Attwood, Alexander Leaflets

4C/4C longwise set

CASHMERE SHAWL 8x32 S

T_R 2 X_L 1	T_R T_L T_R T_L		3 1 2 3 3 1 2 2 1 2x1x3x X_R X_L X_R
--	--	---	---

Iain Boyd, Strathtay Album

3C/4C longwise set.

HOME AND AWAY

Devised by John Wilkinson – October 2014. Revised March 2016.

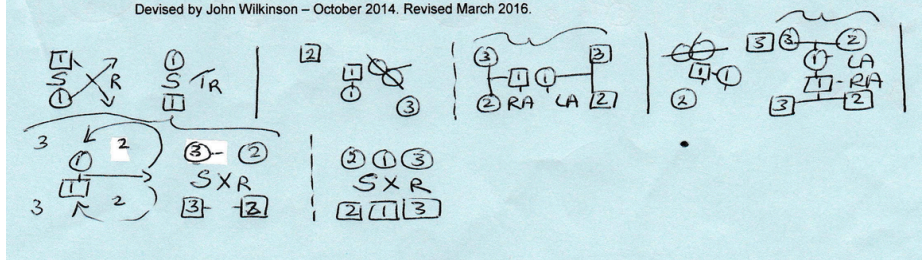

ALISON ROSE 4x32 S

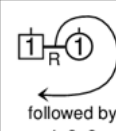
3	S  2 places	Men Women LA RA	Women Men LA RA by changing with partner	 followed by 4 3 2	1x 4x 3x 2x 1 4 3 2 A to 2 3 4 1
----------	--	---------------------------	---	--	---

Derek Ivory, 1968, Imperial Book 2.2

4C/4C longwise set.



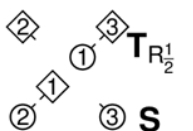
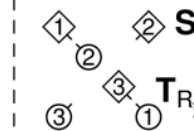
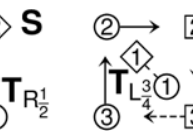
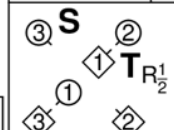
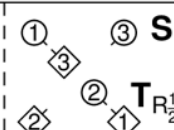
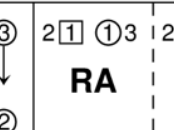

ZYTGLOGGE 8x32 R

T_R 1 T_L			
			2 1 1 3 2 1 1 3 RA LA

Terry Blackburn, 2000

3C/4C longwise set.

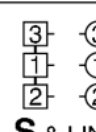
BROADWAY 3x32 S

T_B 	S & LNK RL				3x 1x 2x S T_R¹₂ S
--	------------------------------------	---	---	---	---

Chris Ronald, 2003, Big Apple Collection

3C/3C longwise set.

THE ROSELATH CROSS

8x32 J

Henrietta Vosper, 1998, RSCDS Book 41.10

3C/4C longwise set.

EH3 7AF

8x32 J

Roy Goldring, 1998, RSCDS Book 40.6

3C/4C longwise set.

THE WORLD TURNED UPSIDE DOWN

4C 5C & 6C start on opposite sides

6x32 R

Iain Boyd, 1995, Island Bay Collection 2

6C/6C longwise set.

THE SILVER GREY

3x32 S

Roy Goldring, Graded & Social Dances 2

3C/3C longwise set

WHIGMALEERIES

8x32 R

Derek Ivory, 1968, Imperial Book 2.3

3C/4C longwise set.

THE WILD GEESE

8x32 J

RSCDS Book 24.3

3C/4C longwise set.

THE WATER OF LEITH		4x32 S	
1 3 S		$\overline{1-1} \overline{3-3}$ T _{R₂¹}	$\overline{1-1} \overline{3-3}$
1 2 3 4 RA		<i>Espagnole</i> 	$\overline{4-1}$ T _R T _L

John Wilkinson, Edinburgh 90

4C/4C longwise set.

AIRD OF COIGACH		4x48 J	
<i>Snowball Chain</i>			
$\overline{1-3-4-2}$ X _R	$\overline{2-3-4-1}$ X _L	$\overline{3-2-1-4}$ X _R	$\overline{4-1-2-3}$ X _L

John Bayley, 1975, Imperial Book 3.13

4C/4C longwise set

THE BYRON STRATHSPEY		3x32 S	
1 2 3 T _◇ S	1 2 3 T _{B_{1/4}¹}		
		RA	LA
		A	

John Drewry, 1975, Deeside Book 2

3C/3C longwise set.

MAIRI'S WEDDING		8x40 R	
T _R $\overline{1}$	T _{L_{1/4}¹}		
		R	
			2 1 3

James Cosh, 1959, 22 SCD & 1 other

3C/4C longwise set Skillern, 1776, RSCDS Book 16.3

THE DUKE OF ATHOLL'S REEL		8x32 J	
$\overline{1-2}$ S RA S LA			
		S _{T_R}	S _{T_R}
		X _R $\overline{1}$	RL
			2 1

2C/4C longwise set.

THE IRISH ROVER		8x32 R	
$\overline{2-1}$			T _{L_{3/4}³}
		RA	
		RL	
		RL	

James B Cosh, 22 SCD & 1 other

3C/4C longwise set